

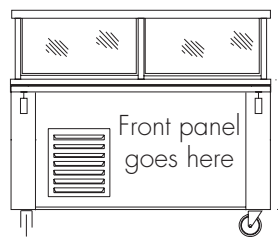

Beyond the Standard

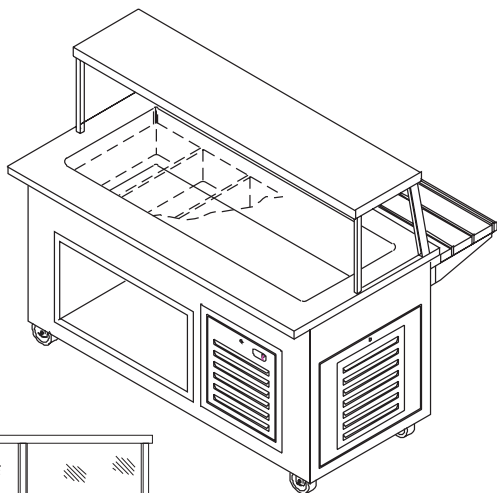

Models

- CLSX-R-2 2 wells, 36" CLSX-R-5 5 wells, 74"
- CLSX-R-3 3 wells, 50" CLSX-R-5-84 5 wells, 84"
- CLSX-R-4 4 wells, 60" CLSX-R-6 6 wells, 96"

- **6 standard sizes available**
- Heavy duty, 14 gauge stainless steel countertops standard
- **Cold pans exceed NSF7 with pans recessed 3" below top**
- Available in 2-6 hot food well models - 1" manifold drains with screens and ball valve (standard)
- Interchangeable front panels create decorative interaction stations.
- Taller and wider food shield allows for optimum merchandising
- Easy to clean, 1/4" tempered glass food shields eliminates scratching and cloudiness.
- 5" heavy duty casters with brakes standard
- Leveling CAM locks at top corners
- 8'-0" cord and plug (standard)

X-STREAMLINE™

Recessed Modular Cold Food Station

Food pans recess 3" below top

Date: _____ Quantity: _____

Item #: _____

Project: _____

Options & Accessories

Countertop

- 36" high (standard)
- Other height, specify: _____
- Recess for 18x26 pans
- Solid surface countertop specify: _____

Counter Front

- Counter front graphics (standard) please specify
- See graphic chart**
- Option 1: Spice Spot
- Option 2: Hot Spot
- Option 3: Refuel Station
- Option 4: Grill n' Chill
- Option 5: Wrap-n-Roll
- Option 6: Chillin' Zone
- Option 7: Field of Greens
- Option 8: Deli Xpress
- Option 9: Taco Island
- Option 10: Xpressly Pizza
- Option 11: Stainless steel panel
- Option 12: Custom Graphic (consult factory)

Color Palette (standard)

- Counter front color palette
- See color chart**
- please specify: _____
- Palette 1: Blue Green
- Palette 2: Orange Red
- Palette 3: Pink Purple
- Palette 4: Green Yellow
- Palette 5: Other _____

Tray Slide

- 12" Stainless steel "V" ridge tray slide (standard)
- 12" Flat stainless steel tray slide
- Continuous top extension (in lieu of separate tray slide) Specify width: _____
- Solid surface tray slide Specify: _____

Options

- Laminated exterior body panels
- Operator serve protector with stainless steel top shelf
- Stainless steel over-shelf
- Self-service food shield with stainless steel top shelf
- Two shelf glass display case
- Two-sided service - Island counter includes security cover over controls
- Powder coated posts, uprights and brackets
- Fluorescent Lights
- Infra-red heat lamp with lights
- Single fill faucet
- Individual hot food drains with ball valves
- Fold down cutting board
 - 5" wide or 8" wide
- Fold down plate shelf
 - 5" wide or 8" wide
- Daisy chain for wiring multiple units together
- Hinged doors
- Heated storage compartment
- Flush mounted duplex outlet
- Pedestal mounted duplex outlet
- Stainless steel legs





X-STREAMLINE™

Recessed Modular Cold Food Station

Beyond the Standard

Food pans recess 3" below top

Item #: _____

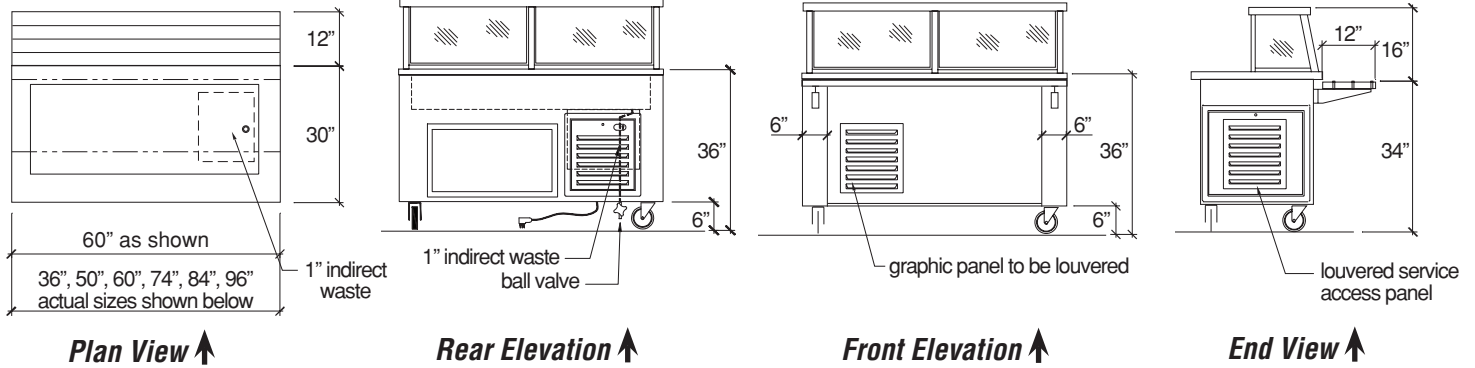

Model	30" Width X Length	Cold pan length	Storage Compartment length	Comp	No. of pans	120V, 1 phase		Approx. weight
						AMPS	NEMA	
□ CLSX-R-2	36 3/8"	25"	n/a	1/3	2	7.5	5-15P	400 lbs
□ CLSX-R-3	50 3/8"	38"	15"	1/3	3	7.5	5-15P	450 lbs
□ CLSX-R-4	60 3/8"	51"	28"	1/3	4	7.5	5-15P	580 lbs
□ CLSX-R-5	74 3/8"	51"	28"	1/3	5	7.5	5-15P	600 lbs
* □ CLSX-R-5-84	84 3/8"	64"	46"	1/3	5	7.5	5-15P	700 lbs
□ CLSX-R-6	96 3/8"	77"	(2) 28"	1/2	6	14	5-20P	750 lbs

* 84" unit has 5 wells but provides additional counter space **Mechanical requirements may change depending on options chosen.

Specifications: Short Form

Provide Multiteria Model # _____ to be constructed with 14 gauge, heavy duty welded stainless steel top. The body to be 18 gauge stainless steel unitized construction. The front panel shall be easily removable and replaceable allowing front service access. Storage compartment comes standard with unit. Counter is mounted on 5" ball bearing, swivel type casters with brakes on all wheels. All units to be provided standard with 8' long cord and plug.

Specifications: Detailed

Counter body is unitized type construction and is of 18 gauge stainless steel with overlapping corners welded in place. Body is reinforced with 12 gauge vertical galvanized steel channel supports.

Front décor panels:

Panels to be 1/2" Sintra board with laminated vinyl graphic print. Panels shall be colorful and interactive in design and shall be easily removable and replace-

able allowing front service access. A stainless steel front panel is available at no additional cost.

Counter Top:

Top to be 30" wide and fabricated from a minimum of 14 gauge stainless steel with square turndown on all sides and corners fully welded, ground and polished. Top to have #4 satin finish and all edges having #7 highlight finish.

Refrigerated Cold Pan:

Cold pan to be 18 gauge stainless steel fully welded construction with 1/4" coved corners. The cold pan shall be pitched to a 1" drain with screen, which is extended to a ball valve below the base. All cold pans shall be furnished with urethane insulation on bottom and all four sides of pan. The pan shall be fully separated from the counter top by a full-perimeter breaker strip. Cold pan to accommodate full steam table pan 6" deep. Temperature is maintained by a static air system utilizing 1/2" copper coils attached to the liner

bottom and sides to a level 1" above the food pans. Cold pan shall be 9" deep and include a patented forced air refrigeration system (hermetic) with built in condensate evaporator. Food pans shall be supported by full length, removable brackets located 3" below the top.

Storage Compartment:

Storage compartment is made of 18 gauge stainless steel. Liner to have coved corners and removable top panels to allow for service access.

Casters:

Counter is mounted on 5" diameter, ball bearing and swivel type casters to be non-marking and with brakes on all wheels. Casters to be mounted through two 12 gauge channels for extra rigidity.



Due to continuing product improvement, units and specifications are subject to change without notice.

(3/2008)