

MODULAR LOCK-N-LOAD OPEN TOP STATION



Item #: _____ Quantity: _____

AIA: _____ Date: _____

Project: _____

Essence Series

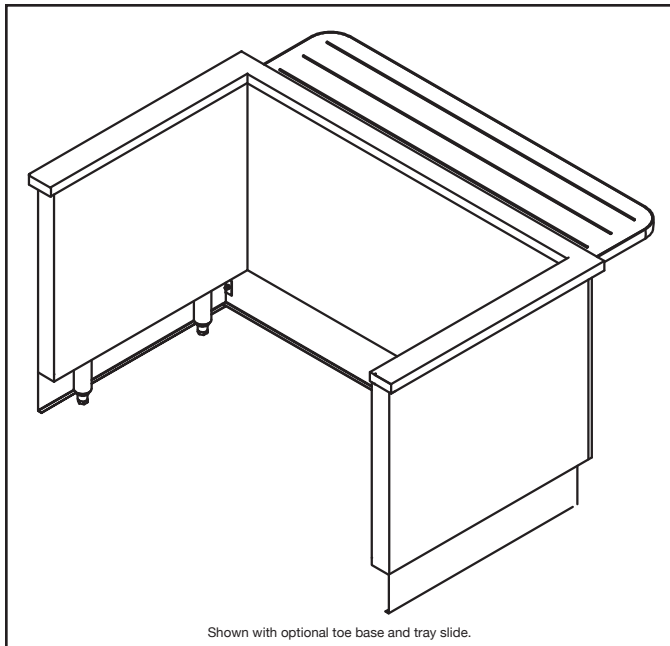

Shown with optional toe base and tray slide.

Create a custom look with unique interlocking modules!

OPTIONS & ACCESSORIES

Countertop Material

- 14 gauge 300 series stainless steel (standard)
- Zodiaq® Quartz
- Corian® solid surface
- Laminate
- Common top (contact factory)

Exterior Panels

- Laminate panels specify mfg./color _____
- Stainless steel panels
- Custom decorative laminate (contact factory)

Service Type

- Operator service

Food Protector Style

- FS (standard)
- VG 1" tubular style

Display Shelves

- Single glass display shelf
- 2-tier glass display shelf

Food Protector Options

- Black powder coat finish
- Stainless steel
- Other powder coat finish (verify) R.A.L. color _____
- Fluorescent lights
- Heat lamp strip with lights

Counter Heights

- 34" high (standard)
- Available between 30" & 36" specify height: _____

Kickplate & Casters

- 6" adjustable stainless steel legs (standard)
- Black powder coated kickplate
- Stainless steel kickplate
- 5" casters

Tray Slide Options

- "V" ridge stainless steel (standard)
- Laminate with plastic tray runners and vinyl edge
- Flat stainless steel
- Zodiaq® Quartz
- Corian® solid surface
- Top extension (in lieu of tray rails)

MODELS

- | | | |
|-----------------------------------|-----------------------------------|-----------------------------------|
| <input type="checkbox"/> LNL-OT30 | <input type="checkbox"/> LNL-OT54 | <input type="checkbox"/> LNL-OT78 |
| <input type="checkbox"/> LNL-OT36 | <input type="checkbox"/> LNL-OT60 | <input type="checkbox"/> LNL-OT84 |
| <input type="checkbox"/> LNL-OT42 | <input type="checkbox"/> LNL-OT66 | <input type="checkbox"/> LNL-OT90 |
| <input type="checkbox"/> LNL-OT48 | <input type="checkbox"/> LNL-OT72 | <input type="checkbox"/> LNL-OT96 |

➤ 12 standard sizes available

- **Tight Link** interlocking mechanism (patent pending) eliminates vertical and horizontal gaps between counters.
- Durable welded 300 series stainless steel tubular frame
- Interchangeable exterior panels match or compliment any décor.
- Common tops available up to 18'-0".
- All food shields utilize 3/8" tempered glass panels to maximize merchandising.
- Interchangeable top configurations available.



MODULAR LOCK-N-LOAD OPEN TOP STATION



Item #: _____

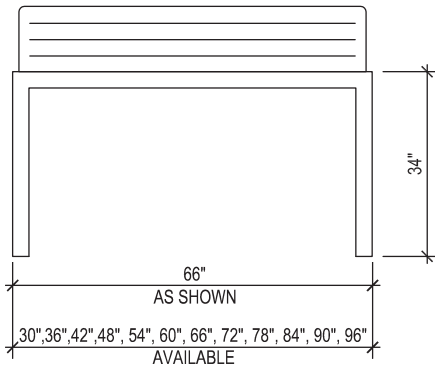

Plan View ↑

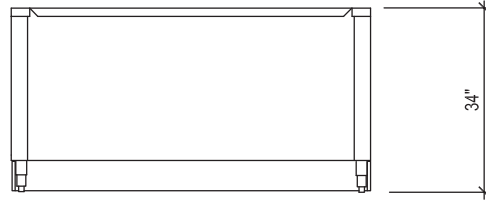

Shown with optional toe base and tray slide.
Verify size of buyout unit.

Elevation View ↑

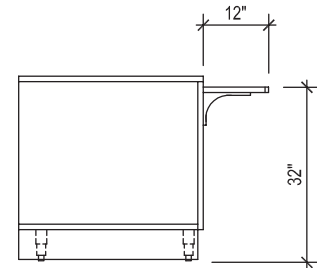

End View ↑

Model	Dimensions LxWxH	Electrical Requirements	Plumbing Requirements	Special Notes
<input type="checkbox"/> LNL-OT30	30"x34"x34"	N/A	N/A	E,H,I
<input type="checkbox"/> LNL-OT36	36"x34"x34"	N/A	N/A	E,H,I
<input type="checkbox"/> LNL-OT42	42"x34"x34"	N/A	N/A	E,H,I
<input type="checkbox"/> LNL-OT48	48"x34"x34"	N/A	N/A	E,H,I
<input type="checkbox"/> LNL-OT54	54"x34"x34"	N/A	N/A	E,H,I
<input type="checkbox"/> LNL-OT60	60"x34"x34"	N/A	N/A	E,H,I
<input type="checkbox"/> LNL-OT66	66"x34"x34"	N/A	N/A	E,H,I
<input type="checkbox"/> LNL-OT72	72"x34"x34"	N/A	N/A	E,H,I
<input type="checkbox"/> LNL-OT78	78"x34"x34"	N/A	N/A	E,H,I
<input type="checkbox"/> LNL-OT84	84"x34"x34"	N/A	N/A	E,H,I
<input type="checkbox"/> LNL-OT90	90"x34"x34"	N/A	N/A	E,H,I
<input type="checkbox"/> LNL-OT96	96"x34"x34"	N/A	N/A	E,H,I

**Mechanical requirements may change depending on options chosen.

Specifications: Short Form

Provide Multiteria Model # LNL-OT ____ to be constructed with heavy duty welded stainless steel tubular frame. Counter top to be manufactured with 14 gauge 300 series stainless steel with 1-1/2" top turndown all welds to be ground and polished to provide #4 finish. Furnish easily removable and interchangeable 3/4" laminated MDF front and end panels. Panels to have prime laminate front and all edges with white laminate interior liner.

Specifications: Detailed

Body Frame: Body to be welded and polished, 1" stainless steel framework. Body frame made to readily accept 3/4" laminated décor panels to allow panel changing without the use of tools. Body frame made to accept Tight Link™ (patent pending) fastening system. Unit shall rest on 6" high stainless steel legs with stainless steel adjustable feet.

Front décor panels: Panels to be 3/4" MDF panels with plastic laminate front, back and edges. Shall be removable by removing tray rail brackets for convenient front access for plumbing and electrical connections or

service. Décor end panels shall be removable without the use of tools.

Counter Top: Top shall be made of 300 series stainless steel with 1-1/2" top turndown, and shall be removable from frame without the use of tools to allow for service, initial installation of mechanicals or remodeling requiring a revised top configuration. Top shall include stainless steel support channels and shall be constructed to accommodate remodeling of the counter at a later date to accept an alternate material top without changing the work height.

Tight Link™ (patent pending)

Furnish with linking system that links adjacent counters together the entire depth and height of the counter. Linking system shall eliminate top, front and rear horizontal and vertical gaps between equipment. Linking system to be open to allow mechanical connections to run through adjoining counters without having to cut access holes reducing the number of building mechanicals required to connect equipment.

NOTES

- A. Cold pan units provided with 115V, 6' 0" cord and plug.
- B. Cold pan drain provided with shutoff valve.
- C. Hot well drains are manifolded and provided with shutoff valve.
- D. Hot food units provided standard with junction box electrical connection. Consult factory for optional connection services.
- E. Standard unit comes with no mechanical connections. Consult factory for optional connection services.
- F. Counters are available with any combination of drop-in units. Consult factory for optional configurations.
- G. 4" access is provided behind undershelf for mechanicals. Specify requirements at time of order.
- H. Common tops are available up to 18' 0" lengths and can be used to decrease number of top seams.
- I. Special custom applications... see specs or drawing.



Due to continuing product improvement, units and specifications are subject to change without notice.

(10/2007)