

OPTIONAL FOOD SHIELDS



Item #: _____ Quantity: _____

AIA: _____ Date: _____

Project: _____

**VERSA-GARD®
VG5**
Self-Service
Protector

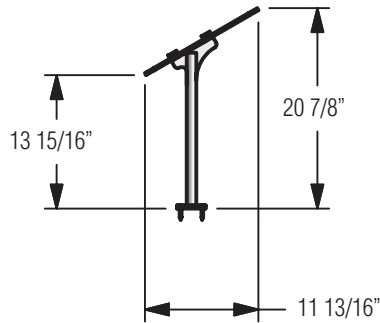
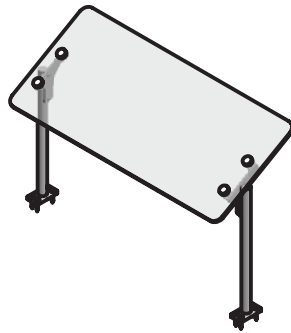

**VERSA-GARD®
VG5A-DS**
Double-Sided
Self-Service
Protector

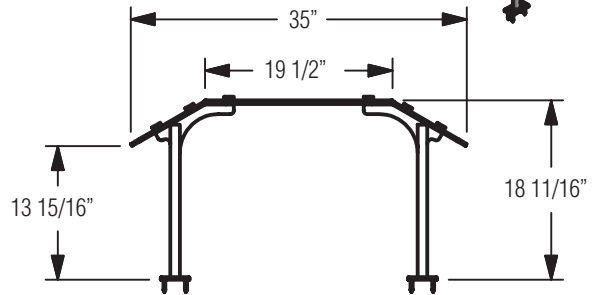
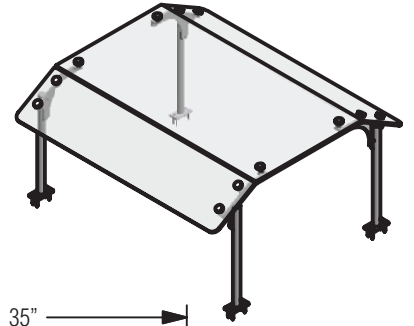

**VERSA-GARD®
VG6R**
Full Service
Protector

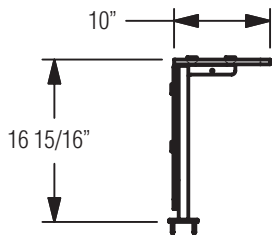
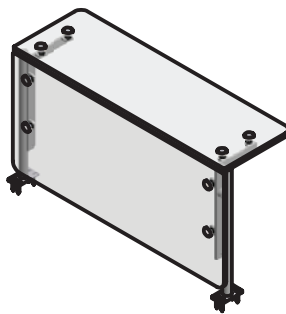

VG5 - Self Service Food Protector

- Clear Tempered Glass Panels w/ radius corners & polished edges
- 1" OD Supports & CNC machined hardware
- Powder Coated Aluminum or Brushed Stainless Steel Finishes
- Side Return Panels available
- NSF2 and UL EPH Listed

VG5A-DS - Double-Sided Self-Service Food Protector

- Clear Tempered Glass Panels w/ radius corners & polished edges
- 1" OD Supports & CNC machined hardware
- Powder Coated Aluminum or Brushed Stainless Steel Finishes
- Side Return Panels available
- NSF2 and UL EPH Listed

VG6R - Full Service Food Protector

- Clear Tempered Glass Panels w/ radius corners & polished edges
- 1" OD Supports & CNC machined hardware
- Powder Coated Aluminum or Brushed Stainless Steel Finishes
- Side Return Panels available
- NSF2 and UL EPH Listed



OPTIONAL FOOD SHIELDS



Item #: _____

VERSA-GARD® VG9-2T

Two-Tier Single-Sided
Display

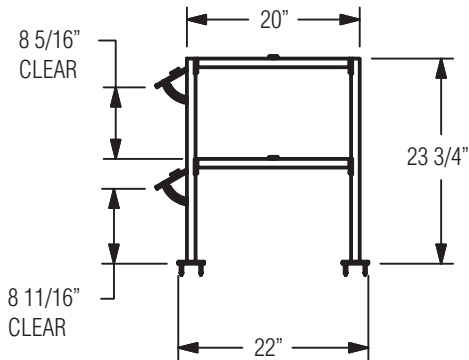
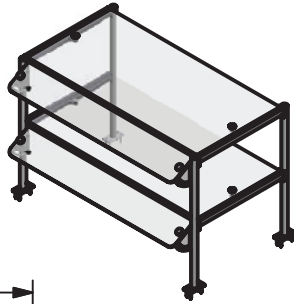

VERSA-GARD® VG9-2T-DS

Two-Tier Double-Sided
Display

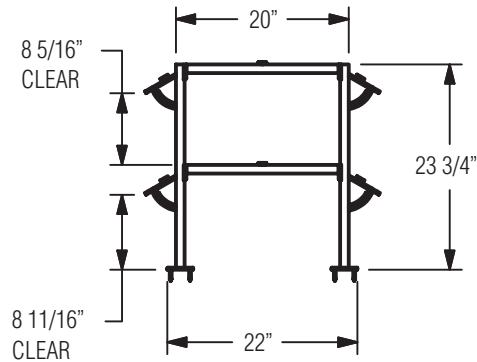

VG9-2T - 2-Tier Self-Service Display

Clear Tempered Glass Panels w/ radius corners & polished edges
1" OD Supports & CNC machined hardware
Powder Coated Aluminum or Brushed Stainless Steel
Side Return Panels available
NSF2 and UL EPH Listed

VG9-DS-2T - 2-Tier Double-Sided Self-Service Display

Clear Tempered Glass Panels w/ radius corners & polished edges
1" OD Supports & CNC machined hardware
Powder Coated Aluminum or Brushed Stainless Steel
Side Return Panels available
NSF2 and UL EPH Listed



Due to continuing product improvement, units and specifications are subject to change without notice. (10/2007)