

MODULAR COLD FOOD STATION

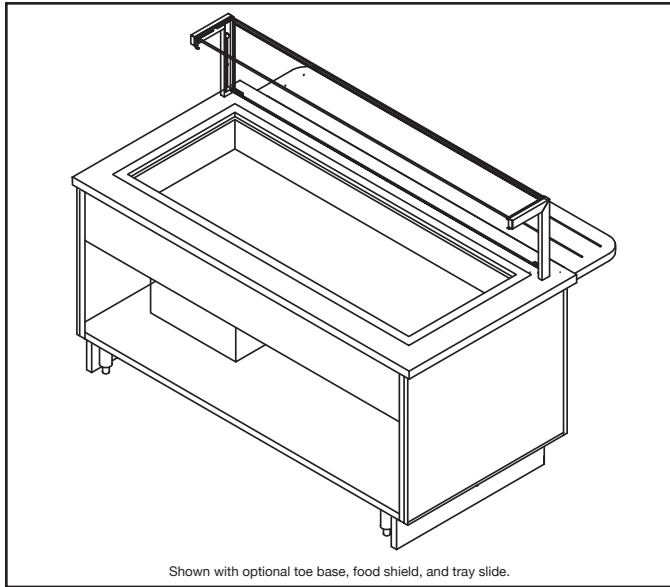

Essence Series



MODELS

- | | | |
|---------------------------------------|---------------------------------------|---------------------------------------|
| <input type="checkbox"/> CLS30 | <input type="checkbox"/> CLS54 | <input type="checkbox"/> CLS78 |
| <input type="checkbox"/> CLS36 | <input type="checkbox"/> CLS60 | <input type="checkbox"/> CLS84 |
| <input type="checkbox"/> CLS42 | <input type="checkbox"/> CLS66 | <input type="checkbox"/> CLS90 |
| <input type="checkbox"/> CLS48 | <input type="checkbox"/> CLS72 | <input type="checkbox"/> CLS96 |

- **12 standard sizes available**
- **Tight Link** interlocking mechanism (patent pending) eliminates vertical and horizontal gaps between counters.
- Durable welded 300 series stainless steel tubular frame
- Available in 1-6 drop in cold pan models
- **NSF-7, 3" recess cold pan standard**
- Optional flush mount NSF-7 standard cold pan available
- Interchangeable exterior panels match or compliment any décor.
- Common tops available up to 18'-0".
- All food shields utilize 3/8" tempered glass panels to maximize merchandising.
- Interchangeable top configurations available.

Item #: _____ Quantity: _____

AIA: _____ Date: _____

Project: _____

Create a custom look with unique interlocking modules!

OPTIONS & ACCESSORIES

Countertop Material

- 14 gauge 300 series stainless steel (standard)
- Zodiac® Quartz
- Corian® solid surface
- Laminate
- Other, specify: _____
- Common top (contact factory)

Exterior Panels

- Laminate panels specify mfg./color _____
- Stainless steel panels
- Custom decorative laminate (contact factory)

Cold Pan

- NSF7 drop-in self-contained cold pan with 3" pan recess (standard) number of pans _____
- Cold pan perimeter bun pan recess
- Insulated ice cooled pan
- Frost top
- Other, specify: _____

Service Type

- Operator service
- Self service (wall unit)
- Two-sided (island)

Food Protector Style

- FS (standard)
- VG 1" tubular

Display Shelves

- Single glass display shelf
- 2-tier glass display shelf

Food Protector Options

- Black powder coat finish
- Stainless steel
- Other powder coat finish (verify) R.A.L. color _____
- Fluorescent Lights

Under Counter Options

- Removable under-shelf (standard)
- Enclosed under-shelf
- Pan slides

Counter Heights

- 34" high (standard)
- Available between 30" & 36" specify height: _____

Kickplate & Casters

- 6" adjustable stainless steel legs (standard)
- Black powder coated kickplate
- Stainless steel kickplate
- 5" casters

Plumbing Options

- Bottom exit with ball valve
- Bottom exit with hosebib
- Recessed gate valve with pipe extension

Tray Slide Options

- "V" ridge stainless steel (standard)
- Laminate with plastic tray runners and vinyl edge
- Flat stainless steel
- Zodiac® Quartz
- Corian® solid surface
- Top extension (in lieu of tray rails)

Operator Work Ledge

- White poly carving board on fixed brackets
- White poly carving board with fold-down brackets

Electrical Options

- Duplex outlet, flush
- Duplex outlet, pedestal

Additional Options

- Bread storage well
- Tray dispenser
- Plate dispenser



MODULAR GOLD FOOD STATION



Item #: _____

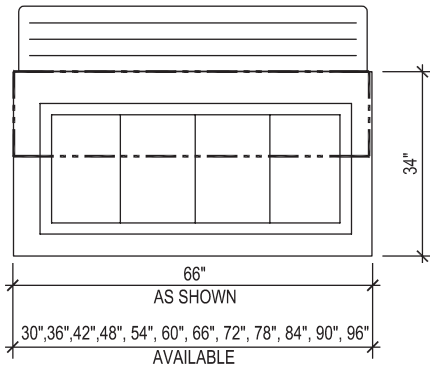

Plan View ↑

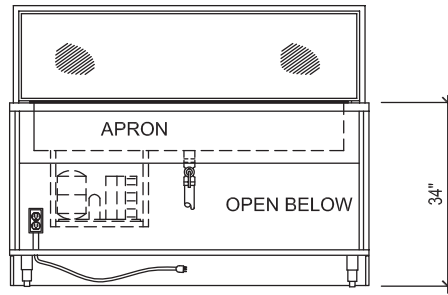

Elevation View ↑

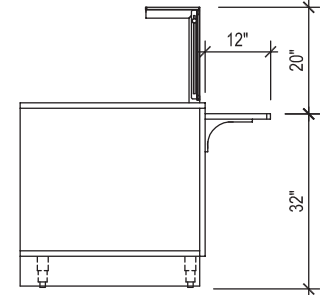

End View ↑

Model	Dimensions LxWxH	Number of pan openings		Electrical (standard 120V,1 phase)			Plumbing Requirements	Special Notes
		available	standard	H.P.	AMPS	NEMA		
☐ CLS30	30"x34"x34"	1	1	1/6	4	5-15P	1" waste	A,B,F,G,H,I
☐ CLS36	36"x34"x34"	1,2	2	1/6	4	5-15P	1" waste	A,B,F,G,H,I
☐ CLS42	42"x34"x34"	1,2	2	1/6	4	5-15P	1" waste	A,B,F,G,H,I
☐ CLS48	48"x34"x34"	1,2,3	3	1/4	7	5-15P	1" waste	A,B,F,G,H,I
☐ CLS54	54"x34"x34"	1,2,3	3	1/4	7	5-15P	1" waste	A,B,F,G,H,I
☐ CLS60	60"x34"x34"	1,2,3,4	4	1/4	7	5-15P	1" waste	A,B,F,G,H,I
☐ CLS66	66"x34"x34"	1,2,3,4	4	1/4	7	5-15P	1" waste	A,B,F,G,H,I
☐ CLS72	72"x34"x34"	1,2,3,4,5	5	1/4	7	5-15P	1" waste	A,B,F,G,H,I
☐ CLS78	78"x34"x34"	1,2,3,4,5	5	1/4	7	5-15P	1" waste	A,B,F,G,H,I
☐ CLS84	84"x34"x34"	1,2,3,4,5	5	1/4	7	5-15P	1" waste	A,B,F,G,H,I
☐ CLS90	90"x34"x34"	1,2,3,4,5,6	6	1/4	7	5-15P	1" waste	A,B,F,G,H,I
☐ CLS96	96"x34"x34"	1,2,3,4,5,6	6	1/4	7	5-15P	1" waste	A,B,F,G,H,I

**Mechanical requirements may change depending on options chosen.

Specifications: Short Form

Provide Multiteria Model # CLS _____ to be constructed with heavy duty welded stainless steel tubular frame. Counter top to be manufactured with 14 gauge 300 series stainless steel with 1-1/2" top turndown all welds to be ground and polished to provide #4 finish. Furnish easily removable and interchangeable 3/4" laminated MDF front and end panels. Panels to have prime laminate front and all edges with white laminate interior liner.

Specifications: Detailed

Body Frame: Body to be welded and polished, 1" stainless steel framework. Body frame made to readily accept 3/4" laminated décor panels to allow panel changing without the use of tools. Body frame made to accept Tight Link™ (patent pending) fastening system. Base to be furnished with removable stainless steel undershelf. Undershelf depth to allow 4" clear open space for mechanical connections during installation.

Unit shall rest on 6" high stainless steel legs with stainless steel adjustable feet.

Front décor panels: Panels to be 3/4" MDF panels with plastic laminate front, back and edges. Shall be removable by removing tray rail brackets for convenient front access for

plumbing and electrical connections or service. Décor end panels shall be removable without the use of tools.

Counter Top: Top shall be made of 300 series stainless steel with 1-1/2" top turndown, and shall be removable from frame without the use of tools to allow for service, initial installation of mechanicals or remodeling requiring a revised top configuration. Top shall include stainless steel support channels and shall be constructed to accommodate remodeling of the counter at a later date to accept an alternate material top without changing the work height.

Cold Well Units: Drop in, self contained cold pan units shall include drain and drain shut-off valve as standard equipment.

Tight Link™ (patent pending)

Furnish with linking system that links adjacent counters together the entire depth and height of the counter. Linking system shall eliminate top, front and rear horizontal and vertical gaps between equipment. Linking system to be open to allow mechanical connections to run through adjoining counters without having to cut access holes reducing the number of building mechanicals required to connect equipment.

NOTES

- A. Cold pan units provided with 115V, 6' 0" cord and plug.
- B. Cold pan drain provided with shutoff valve.
- C. Hot well drains are manifolded and provided with shutoff valve.
- D. Hot food units provided standard with junction box electrical connection. Consult factory for optional connection services.
- E. Standard unit comes with no mechanical connections. Consult factory for optional connection services.
- F. Counters are available with any combination of drop-in units. Consult factory for optional configurations.
- G. 4" access is provided behind undershelf for mechanicals. Specify requirements at time of order.
- H. Common tops are available up to 18' 0" lengths and can be used to decrease number of top seams.
- I. Special custom applications... see specs or drawing.



Due to continuing product improvement, units and specifications are subject to change without notice.

(10/2007)